

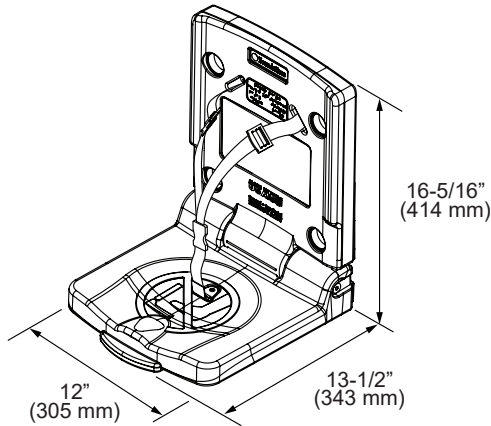

BABY CHANGERS MADE BY BABY EXPERTS.™

Submittal Sheet

Model 5806086 Folding Surface-Mounted Wall Seat



Recommended Blocking

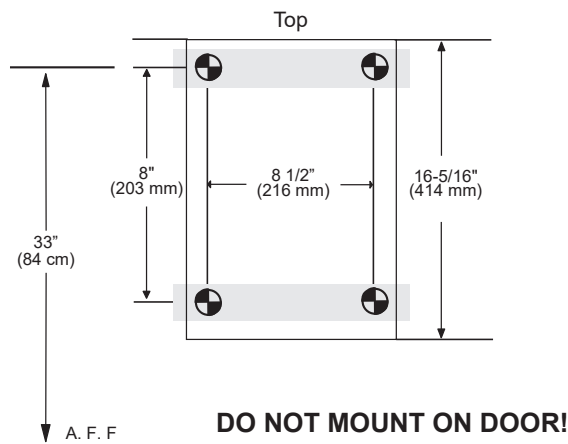

- Keeps child safely off restroom floor.
- Three point safety harness secures child.
- Steel to steel support hinges.
- Rated to support a static load of 50 pounds (22.8 kg).
- Concave seat area features molded in pictogram that illustrates “do not use as a step”.
- Easy to sanitize surface folds out of way when not in use.
- Easy to read ANSI compliant labels (ANSI Z535.3 and ANSI Z535.4), utilizing universal safety symbols.
- Compact, slim profile meets A.D.A. when properly installed. Only protrudes 3 inches or 76mm from wall.
- Includes easy to install, step-by-step instructions plus all mounting hardware.
- ASTM G21 Anti-Bacterial: No measurable bacterial growth.
- Standard pack: 1 unit.
- Limited Warranty: This product is warranted against manufacturing defects for a period of 5 years.

Short Specifications

- Polyethylene Child Wall Seat:
1. Acceptable product: Foundations Worldwide, Inc.; Model 5806086 (formerly 103-BQS).
 2. Characteristics:
 - a. Type: Molded FDA approved high-density polyethylene (HDPE) body.
 - b. Rated to support a minimum static load of 50 pounds or 22.8 kg.
 - c. Child Protection strap featuring three-point safety harness.
 3. A.D.A. Compliance:

	307.2 Maximum Protruding Objects
	308.2 Forward Reach
	308.3 Side Reach
	309.4 Operation
	Compliant when properly installed.
 4. ANSI compliant safety labels.
 5. CPSIA compliant to applicable sections.

Installation Information

- Closed unit projects less than 3 inches (76 mm) from wall.
- Open seat projects 13-1/2 inches (343 mm) from the wall.
- Overall closed dimensions are 12 inches (305 mm) wide and 16-5/16 inches (414 mm) tall.
- Hardware allows for mounting to current or new construction applications.