

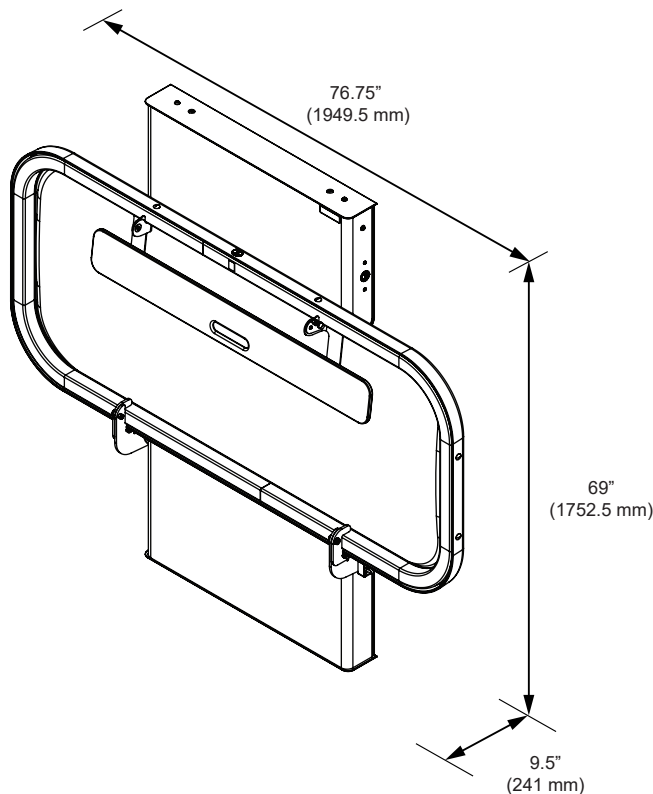

CHANGING STATIONS FOR A CHANGING WORLD.™

Submittal Sheet

Model 800SS-01 Ascent Universal Changing Table

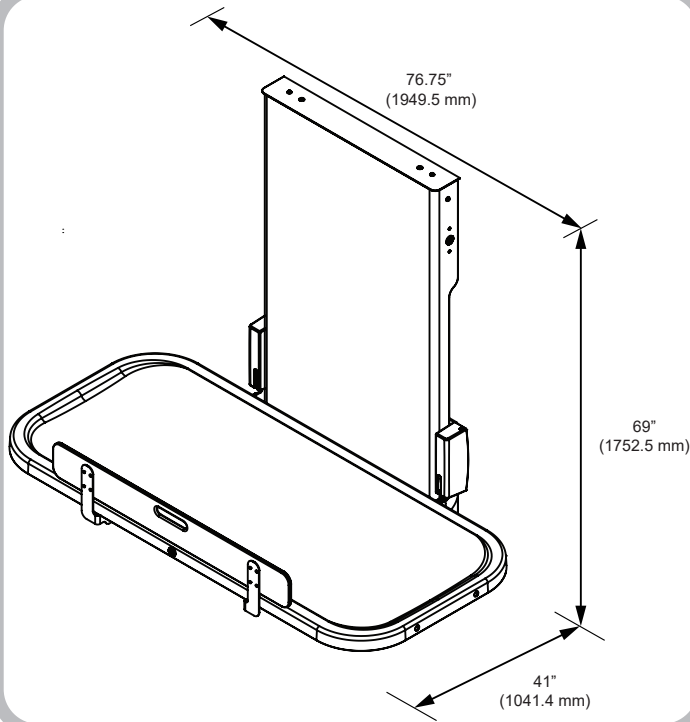

- Designed and engineered to meet the standards in the International Building Code (IBC)
- Automatic retracting feature stops operation and reverses direction when obstruction is detected.
- Unit needs to be plugged into a 120v 20A GFCI outlet. If a duplex outlet is being used the installer needs to ensure it is part of a GFCI protected circuit.
- Overall table surface size of 76.5" x 34.75", with a usable tray size of 70.5" x 31.125".
- Two control button locations (on tray and side of shroud) for tray height adjustability (16" – 39" range).
- Battery backup provides safe use in power outage.
- Limited Warranty: This product is warranted against manufacturing defects for a period of 5 years.

Short Specifications

1. Acceptable product: Foundations Worldwide, Inc.; Model 800SS-01 (Ascent Universal Changing Table)
2. Characteristics:
 - a. 304 Brushed stainless steel shroud
 - b. Vacuum formed ABS changing surface
 - c. Powder coated steel frame
 - d. Direct actuator
 - e. Hinged tray guard
3. Load rating of up to 500lbs (226 kg)
4. Class 1 Electrical system to protect against electrical shock
5. Complies with UL 962 certification & CSA22.2 No. 68
6. Unit is IPX6 rated
7. IK10 Impact Rating

Installation Information

- Reference Pre-Installation Guide and Assembly Instructions for more detailed information, including recommended blocking.
- Closed unit projects from wall 9.5 inches (241mm).
- Open changing surface projects 41" inches (1041.4 mm).
- Unit needs to be plugged into a 120v 20A GFCI outlet. To maintain a water ingress rating, ensure an appropriate While-in-use cover is installed.