

**M23A-UL / M23AB-UL / M23ABT-UL / M23ACS-UL**

**General Description**

- The U-flow is a fast, energy, efficient, environmentally friendly, hygienic & stylish hand dryer, suitable for high traffic facilities. Surface ADA-compliant (Installed according to recommended mounting height)
- "Hands-thru" model, it has one pair of IR sensors on both upper sides for instant hand detection.
- Maximum air speed 196mph.
- Dries hands in only 8 / 10 seconds.
- Adjustable motor power, allowing electricity consumption to be regulated between 350 and 1,300W.
- HEPA media filter that filters the solid particles in suspension (pollen, dust mites, tobacco smoke, etc.) significantly improving air quality, and with an anti-theft system as standard.
- It is delivered with an ionizer ("Ion Hygienic" technology) as standard that purifies the air through negatively charged particles (anions), eliminating many of the particles and germs carried by the air, making it healthier and pure. These ions inhibit the reproduction of micro-organisms in the product throughout its lifetime.
- Plug-in system as standard that facilitates a safer, more efficient and faster connection to the machine.
- With Biocote® that reduces the growth of microbes such as bacteria and mould by up to 99.9%.
- 30 seconds safety timer.
- Lowest noise level in its category. (72.5-76.5 dBA).
- Easy maintenance, it can be connected directly to the main waste pipe of the bathroom to eliminate waste water from hand drying. Connection pipe as standard.
- Removable water tank with optional anti-theft system.



Please mark the selected item



code

M23A-UL

material  
high impact ABS  
finish  
white finish



code

M23AB-UL

material  
high impact ABS  
finish  
black finish



code

M23ABT-UL

material  
high impact ABS  
finish  
All black finish



code

M23ACS-UL

material  
high impact ABS  
finish  
satin finish

**Components & Materials**

- **COVER:** made of high impact ABS.
- **BASE PLATE:** made of plastic PA6V0.
- **MOTOR:** high-speed class F universal brush motor, adjustable from 19,000 to 28,000 rpm, allowing electricity consumption and sound pressure to be regulated.
- **HEATING ELEMENT:** of 250W, made of a wavy wire and mounted on a mica frame.
- **HEPA MEDIA FILTER:** cartridge that holds an HEPA media filter that filters suspended solid particles (pollen, dust mites, cigarette smoke, etc.), notably improving the air quality. Furthermore, this cartridge also contains an activated carbon filtering media that neutralizes odors and absorbs smokes and gases, helping avoid bad odors. It comes as standard.
- **IONIZER:** cleans and purifies the air through negative ions (anions) which remove microscopic particles from the air making it healthier. It comes as standard.
- **CONNECTION TO THE WASTE PIPE:** Included from the factory with the hand dryer. It can be connected directly to the waste pipe. Thus, there is no need to empty the water tank because the water always goes directly to the waste pipe.
- **INNER TANK:** collects the water. It is removable. Also, the U-flow can be connected directly to the waste pipe.
- **AUTO-CHECK LIGHTING:** for fast diagnosis of the dryer (green - Stand by, yellow - machine running, blue - full tank, red - check engine). Optical and acoustic full tank warning.
- **ODOR NEUTRALIZER:** for a cleaner and more pleasant atmosphere in the bathroom. (Optional).



Saniflow Corp reserves the right to make changes and/or modifications to the products and their specifications without warning or notice.

## Technical Specifications

Voltage - 100-120V; 208V; 220-240V	Total power – 350-1,300 W
Frequency - 50/ 60 Hz	Motor Power – 350-1,050 W
Insulation - Grounding required (Class I)	Heating element power: 0 or 250 W
Dimensions - 21 7/8"H x 13 1/2"W x 8"D	Consumption
	3-10.8 A H.Element "ON" 3 - 9A H.Element "OFF"
Weight - 15,7 Lbs.	r.p.m. - 19,000-28,000 rpm
Effective airflow - 66 CFM	Air temperature – (at 4" distance/ T amb. 70 °F) 102 °F
Max air velocity - 196 mph / 17.280 LFM	Drying time - 10 – 12 sec
Protection level - IP23	Noise level (at 79") - 72,5 – 76,5 dBA

## Operation

Place your hands between the air outlets, in the "U" area, near the IR sensors.

The dryer will start automatically and remain on with no interruption as long as your hands are kept in the detection range of the sensor. Move your hands as you like but always within the detection range of the sensors. The appliance will stop 2 seconds after your hands are removed from the airflow.

## Installation

Verify all rough-in dimensions prior to installation. Hand dryers require a dedicated circuit and must be properly grounded. a GFCI (Ground fault circuit interrupter) is recommended. One side of dryer show be mounted to a stud.

## Certificates & Qualifications

Fulfill ADA requirements for a barrier-free washroom. Unit shall be UL and CSA approved, according to UL 499, CSA C22.2 standars.

## N° dryers to be fittedz

- In toilet areas with a normal frequency of use and only one wash-basin: 1 dryer.
- In toilet areas with a normal frequency of use and more than one wash-basin: 1 dryer for each 2-3 wash-basins.
- In toilet areas with multiple wash basins: 4 wash basins: 2 dryers; 1 row of 6 wah basins: 2-3 dryers; 1 row of 8 wash basins: 3 dryers.

## Ideal location

Between the wash-basin and exit. It is not recommended to install dryer between wash-basins, next to urinals, lavatories and showers. If installing automatic dryers over marble surface or ledge, the minimum distance from the dryer to the ledge must be 15-3/4". It is recommended that hand dryers be distributed throughout the washroom area to avoid overcrowding.

## Guide specification

Surface-mounted ADA-compliant hand dryer shall have ABS cover with white finish (M23A-UL), black finish (M23AB-UL), all black finish (M23ABT-UL), or satin finish (M23ACS-UL). Hand dryer shall include a fire resistant UL V0 plastic base, fully adjustable (2" to 8") infrared sensor and fully adjustable (19,000 - 28,000 RPM) universal brush motor. Dryer shall operate at 72,5-76,5 dBA while delivering 66 CFM of air at 102 °F and 196 mph as maximum air velocity (Max - 20,468 LFM) during user controlled drying cycle. Dryer shall have a total power of 350-1,300 W with a consumption of 3 to 10.8 A. Hand dryer shall assembly an HEPA filter media which filters the solid particles in suspension (pollen, dust mites, tobacco smoke, etc.) significantly improving air quality and an ionizer (Ion Hygienic Technology) which cleans and purifies the air through negative ions (anions) removing microscopic particles from the air and make it healthier

Unit shall be UL and CSA approved, according to UL 499, 13th Edition, CSA C22.2 standards.

## MOUNTING

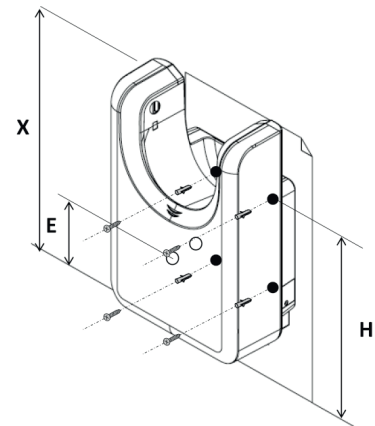

## M23A-UL / M23AB-UL / M23ACS-UL / M23ABT-UL

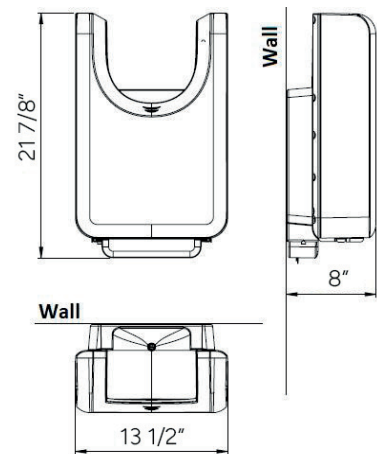

## Serial mounting

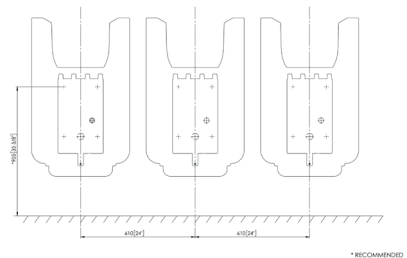

Saniflow Corp reserves the right to make changes and/or modifications to the products and their specifications without warning or notice.

---





---

**Overall dimensions:**

21 7/8"H x 13 1/2"W x 8"D (557 mm x 344 mm x 202 mm)

Weight: 15.7 Lbs. (7.1 Kg)

**Recommended heights  
from floor**

	 Male	 Female	 Child	 Disabled
<b>X</b> To top of machine	35-5/8" / 905 mm	35-5/8" / 905 mm	35-5/8" / 905 mm	35-5/8" / 905 mm
<b>H</b> To mounting brackets	35-7/8" / 905 mm	35-7/8" / 905 mm	35-7/8" / 905 mm	35-7/8" / 905 mm
<b>E</b> To sensor top	28-3/4" / 730 mm	28-3/4" / 730 mm	28-3/4" / 730 mm	28-3/4" / 730 mm

Job:

Model number:

Variations:

Architect / Engineer:

Contractor:

Customer / Wholesaler:

City / State / Country:

Date:

Quantity:

---

Saniflow Corp reserves the right to make changes and/or modifications to the products and their specifications without warning or notice.

---

Allied Hand Dryer, Ltd.  
706 W Summit Ave  
San Antonio, TX 78212

800.535.4393  
210.733.5918  
210.308.5924 Fax

[www.handdryer.com](http://www.handdryer.com)  
[sales@handdryer.com](mailto:sales@handdryer.com)